

## Free Space Optics Systems

## OPTICOMM-VIDEO

Optical Signal Transmission Through The 'Free' Atmosphere

Video CCIR 5.5 MHz

Audio 3.3 kHz

F/O 16 Mb/s

### FEATURES

- Parallel transmission of Video, Audio and Digital Signals
- Simplex video transmission to standard CCIR 5.5 MHz
- Fibre optic interface for parallel LAN applications
- Full duplex audio signal transmission 3300 Hz
- Immunity to electromagnetic interference (EMI)
- Highest signal transmission security and privacy
- Installation distances up to 4000 m
- Installation within a few hours
- Rugged, weatherproof design



OC-VIDEO eB031

**Systems Description**

The Free Space Optics (FSO) systems OPTICOMM-VIDEO developed and manufactured by OPTEL employ modulated laser light for directed transmission of signals through the atmosphere.

In urban and inaccessible environments FSO systems offer an ideal, economical alternative to expensive leased lines for providing highly secure point-to-point signal transmission links between buildings.

Costs for planning and implementation of a signal transmission link bridging roads, railway lines or waterways are minimal, as the main expenses are reduced to the installation of cable only in the customer’s buildings.

Due to the modular design of electronics and interfaces, OPTICOMM-VIDEO systems are offered from basic simplex links for the connection of a camera to a monitor, to the combination of a simplex video link with full duplex audio or data connections.

A multimode fibre optic interface allows the parallel connection of Ethernet networks.

All OPTICOMM transceiver units incorporate a semiconductor laser transmitter and a laser receiver for the atmospheric signal transmission, that are completely independent in their function to allow signal transfer in full duplex mode.

The laser transmitter transforms electrical signals into infrared light signals, which are propagated along the line of sight to the laser receiver of the oppositely installed transceiver unit. The laser receiver picks up the laser light signals and transforms them back into their original electrical form.

The OPTICOMM systems consist of two compact weatherproof transceiver units of rugged design for operation outdoors in almost any environment. Stainless steel weather-protection covers for the housing and protection tubes for the optics additionally shield the transceiver units from the direct effects of sun and rain.

The OPTICOMM-VIDEO transceiver units are mounted in the mutual unimpeded line of sight and are easily aligned by means of alignment telescopes.

The coaxial design of laser transmitter and laser receiver in the OPTICOMM transceiver units, ensures easy, straightforward systems alignment and long-term stable, service-free operation.

**Installation Distances**

The OPTICOMM-VIDEO systems are available in four performance classes to suit varying range requirements.

	Min. Distance	Max. Distance
OC-VIDEO 40x	10 m	400 m
OC-VIDEO 100x	50 m	1000 m
OC-VIDEO 200x	50 m	2000 m
OC-VIDEO 500x	250 m	4000 m

Systems of a higher performance class offer higher link availabilities due to higher power margins, if installed at the same distance.

**General Technical Data**

Optical Transmitter	Semiconductor Laser			
Laser Classification (IEC 60825-1/A2:2001)	Class 3 B			
Optical Receiver	Photodiode			
<b>Model OC-VIDEO ..</b>	<b>..40x</b>	<b>..100x</b>	<b>..200x</b>	<b>..500x</b>
Available Range Combinations	400 m	1000 m	2000 m	4000 m
Minimal Installation Distance	10 m	50 m	50 m	250 m
Nominal Safe Viewing Distance	12 m	18 m	6 m	21 m
-Extended Safe Viewing Distance	100 m	145 m	60 m	165 m
Transmitting Angle (Far Field)	2 mrad	2 mrad	2 mrad	1.5 mrad
Signal Interfaces				
Video Simplex In	CCIR standard 25 Hz - 5.5 MHz, 1 V <sub>pp</sub> , 75 Ohms			
Video Simplex Out	CCIR standard 25 Hz - 5.5 MHz, 1 V <sub>pp</sub> , 75 Ohms + 10,7 MHz Sound Sub-Carrier @ -20 dB			
Optional				
Audio Simplex/Duplex In/Out	300 Hz - 3300 Hz, 1 V <sub>RMS</sub> , 600 Ohms			
Data Full Duplex In/Out	RS-422A 19,2 kb/s			
LAN Full Duplex In/Out	Multimode F/O 820 nm, 200 kb/s - 16 Mb/s			
Supply Voltage	230 VAC ±10%			
	optional	24 VDC ±20%		
Power Consumption	max. approx. 15 VA			
Protection Rating	IP 65			
Operating Temperature	-20°C ... +50°C			
Weight per Transceiver Unit	5.5 kg			
incl. Alignment Base,	20 kg			
Weather Protection				
Alignment Telescope	3 - 9 x 40 mm			
Dimensions L x W x H	460 x 156 x 156 mm			
incl. Weather Protection	1010 x 170 x 170 mm			

**Standard Interface Combinations**

OC-VIDEO 401 - OC-VIDEO 5001	Video Simplex
OC-VIDEO 403 - OC-VIDEO 5003	Video Simplex + Audio Simplex
OC-VIDEO 405 - OC-VIDEO 5005	Video Simplex + Data Duplex
OC-VIDEO 406 - OC-VIDEO 5006	Video Simplex + Audio Duplex
OC-VIDEO 407 - OC-VIDEO 5007	Video Simplex + Audio Duplex + Data Duplex
OC-VIDEO 408 - OC-VIDEO 5008	Video Simplex + Audio Duplex + LAN Duplex
OC-VIDEO 409 - OC-VIDEO 5009	Video Simplex + LAN Duplex

Other interfaces and combinations upon request

**Mechanical Outline**

**OPTICOMM Transceiver Unit**  
 with **Weather Protection Cover** and **Optic Protection Tube**  
 mounted on **Standard Angled Alignment Base**

Mounting Holes: 4 x 11 mm  $\phi$       Hole Pattern: 80 mm x 80 mm

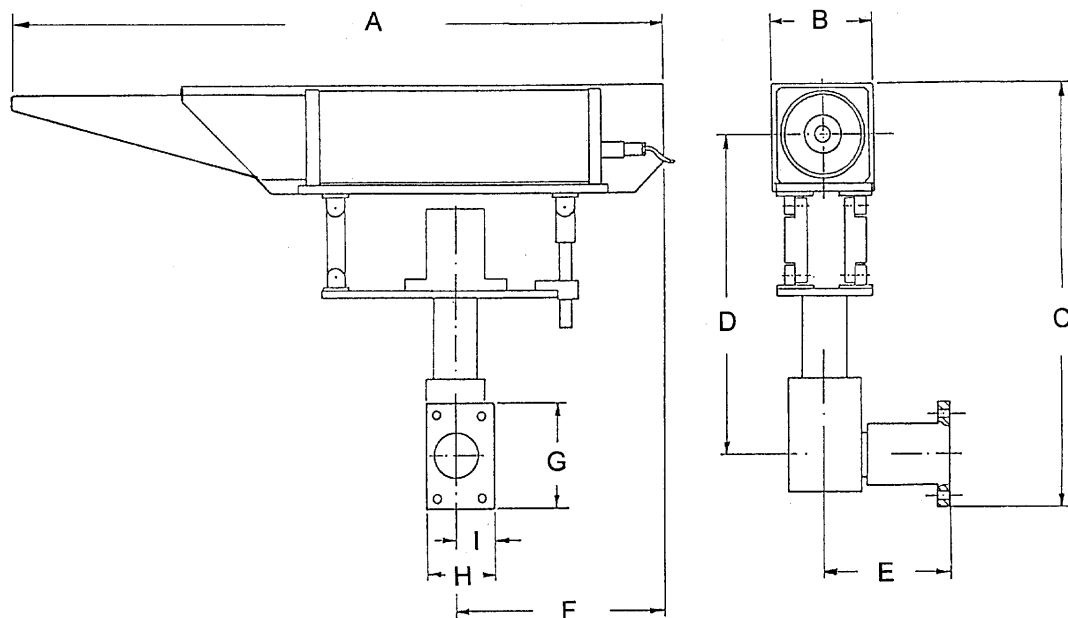

System	A	B	C	D	E	F	G	H	I
OC-VIDEO 401	890	140	555	405	min. 160	290	110	110	55
OC-VIDEO 40x - 500x	1010	170	580	420		310			

Alle Maße in mm

FREE SPACE OPTICS SYSTEMS

OPTICOMM-VIDEO

**Contacts:**

**OPTEL Gesellschaft für Lasertechnik und Elektronik mbH**  
**Holzoppel 1, 22869 Schenefeld / Hamburg, Germany**

www. Optel.com  
eMail: Info@Optel.com  
Phone: (+49 40) 830 99 360  
Fax: (+49 40) 830 99 362

**OPTEL-Service**

eMail: Service@Optel.com  
Mobil: (+49 172) 5154 360